

STABILIZER MODEL: TD-EML/S-CR-#0A

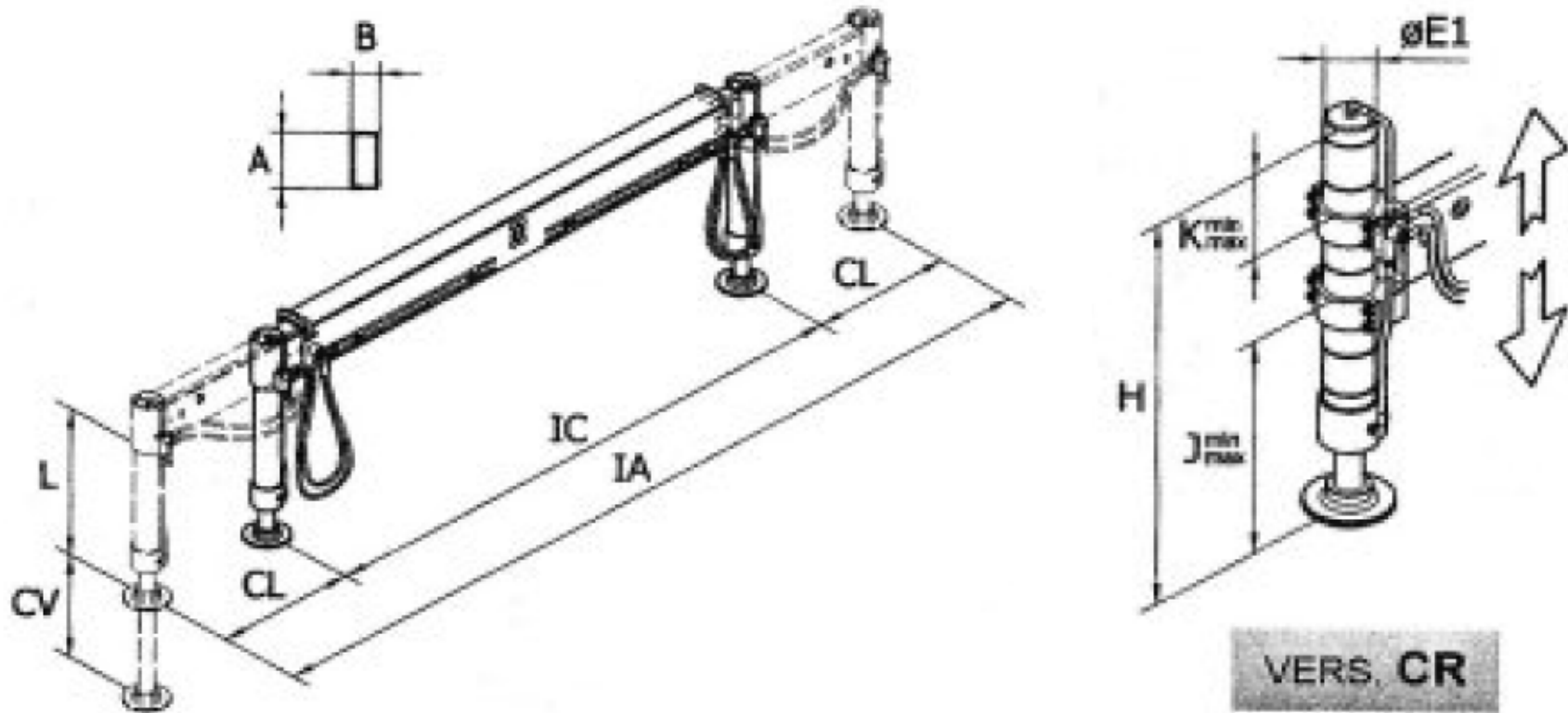

		DIMENSIONS										WEIGHT	CYLINDER DIMENSIONS		
		IC	CL	IA	AxB	L	CV	P	E	S	H		E1	J min-max	K min-max
Metric		1800	500	2800	120x80	40	355	160	70	40	530	95	75	195-345	65-215
Standard		70.87	19.68	110.24	4.72 x 3.14	1.57	13.98	6.30	2.76	1.57	20.87	209.43	2.95	7.67 x 13.58	2.55 x 8.46